

DO NOT SCALE FROM THIS PRINT

DIMENSIONS ARE IN INCHES		UNLESS OTHERWISE NOTED		TOLERANCES ARE:	
ONE PLACE DECIMALS ±.1 [2.5mm]	THREE PLACE DECIMALS ± .005 [.13mm]	ANGLES ± 2°			
TWO PLACE DECIMALS ± .010 [25mm]	FOUR PLACE DECIMALS ± .0020 [0.05mm]				

TITLE: HIGH TEMP 2MM SMT BOARD STACKING TERMINAL STRIP ASM  
 DWG NO: TW-XX-XX-XXX-X-XXX-SM-XXX-XX  
 SHEET 1 OF 3

TABLE 1

LEAD STYLE	TERMINAL	MAX "A" ("B" IS .000 [.00] MIN)	"C" OVERALL PIN LENGTH
-02	T-1S13-02-XXX-2	.309 [7.85]	.377 [9.6]
-03	T-1S13-03-XXX-2	.467 [11.86]	.535 [13.6]
-04	T-1S13-06-XXX-2	.487 [12.37]	.555 [14.1]
-06	T-1S13-10-XXX-2	.605 [15.37]	.673 [17.1]
-07	T-1S13-11-XXX-2	.683 [17.35]	.751 [19.1]
-09	T-1S13-13-XXX-2	.388 [9.86]	.456 [11.6]

NOTES:

- MAX. PIN ROTATION IN BODY: 2°
- PUSHOUT FORCE SHALL BE 1 lb MIN.
- Ⓢ REPRESENTS A CRITICAL DIMENSION
- ALL DIMENSIONS IN BRACKETS [ ] ARE MILLIMETERS.
- HEIGHT VARIATION BETWEEN ANY TWO PINS SHALL BE .010 MAX
- Ⓢ TUBE POSITIONS -04 THROUGH -36 ONLY; LAYER PACKAGE -02 & -03. TUBE PLUG MUST BE ALLIGNED WITH INSULATOR. (SEE DETAIL ON PAGE 2)
- MOLDED OR STAKED ALIGNMENT PIN AT SAMTEC'S DISCRETION.
- SPACE OPTION FROM .170 TO .209 REQUIRES AN ADDITIONAL PREPRESS.
- MUST USE CARBIDE BLADES.
- Ⓢ -M OPTION AVAILABLE ON -D ROW ONLY. -M OPTION AVAILABLE ON POSITIONS 4-36 ONLY. -P OPTION AVAILABLE ON 4-36 POSITION ONLY.

TW-XX-XX-XXX-X-XXX-SM-XXX-XX

No. OF POSITIONS  
 EXPRESSED IN # OF POS  
 (-02 THRU -36)  
 "XX" = No OF POS x .07874 [2.00]

LEAD STYLE  
 (SEE TABLE 1)

PLATING

- G: GOLD (USE T-1S13-XX-G-2)
- T: TIN (USE T-1S13-XX-T-2)
- S: SELECTIVE (USE T-1S13-XX-S-2)
- E: EXTRA HEAVY GOLD (USE T-1S13-XX-E-2)
- L: LIGHT GOLD (USE T-1S13-XX-L-2)
- F: FLASH SELECTIVE GOLD (USE T-1S13-XX-F-2)
- P: GOLD FLASHED PALLADIUM NICKEL (USE T-1S13-XX-P-2)
- TL: TIN/LEAD (USE T-1S13-XX-TL-2)
- STL: SELECTIVE TIN/LEAD (USE T-1S13-XX-STL-2)
- LTL: LIGHT SELECTIVE TIN/LEAD (USE T-1S13-XX-LTL-2)
- H: HEAVY GOLD (USE T-1S13-XX-H-2)
- SM: HEAVY GOLD SELECTIVE, MATTE TIN TAIL (USE T-1S13-XX-S-2)
- TM: MATTE TIN (USE T-1S13-XX-T-2)
- LM: LIGHT GOLD SELECTIVE, MATTE TIN TAIL (USE T-1S13-XX-L-2)
- FM: FLASH GOLD SELECTIVE, MATTE TIN TAIL (USE T-1S13-XX-F-2)

ROW OPTION

- S: SINGLE ROW (USE TMM-50-S)
- D: DOUBLE ROW (USE TMM-50-D)

OPTION 1

- LC: LOCKING CLIP (SEE FIG 2, SHEET 2)  
 (-D ROW: USE 2TS-XX-D)  
 (-S ROW: USE 2TS-XX-SV)  
 (.190 MIN BOARD SPACE)
- A: MOLDED ALIGNMENT PIN (SEE FIG 3, SHEET 2 & NOTE 7)  
 (AVAILABLE IN 2-36 POSITIONS)  
 (2 POSITIONS WILL ONLY HAVE ONE ALIGNMENT PIN)  
 (-D ROW: USE 2TS-XX-DV-A)  
 (-S ROW: USE 2TS-XX-SV-A)  
 (BOTTOM BODY ONLY, USE TMM-50-X FOR TOP)  
 STAKED ALIGNMENT PIN (SEE FIG 4, SHEET 2 & NOTE 7)  
 (-D ROW ONLY: USE TMM-50-D, 5 POS MIN)  
 (.190 MIN BOARD SPACE FOR BOTH)
- P: PICK & PLACE PAD (SEE NOTE 10)  
 (-D ROW: USE PPP-10)  
 (-S ROW: USE PPP-11)  
 NOTE: "B" = .075 [1.91] MIN FOR THIS OPTION (SEE FIG 6)
- M: METAL PICK & PLACE PAD (SEE NOTE 10)  
 (-D ROW: USE PPP-10)  
 NOTE: "B" MUST BE .075 OR GREATER FOR THIS OPTION. (SEE FIG. 5)
- TR: TAPE AND REEL PACKAGING  
 (-07 LEAD STYLE NOT AVAILABLE IN T & R)  
 (SEE SHEET 3 FOR -S-TR OPTION ORIENTATION VIEW)  
 (.475 MAX "A" WHEN COMBINED WITH -P OPTION)

OPTION 2

- XXX: POLARIZED POSITION (SPECIFY OMITTED PIN)

SPACE OPTION

(SEE NOTE 8)  
 XXX="A" (SEE TABLE 1, .170 [4.32] MIN)

TABLE 2 (SEE NOTE 6)

LEAD STYLE	OPTIONS	TUBE	PLUGS
-02, -04, -07, -09	-D, -D-LC, -D-A	PT-TW001-D-SM	TP-03
-03	-D, -D-LC, -D-A	PT-TW001-D-SM	TP-03
ALL	-S, -S-LC, -S-A	PT-TW002-S-SM	TP-03
-02, -09	-D-A-P, -D-LC-P, -D-P, -D-LC-M, -D-A-M, -D-M	PT-TW001-D-SM	TP-03
-03, -04	-D-A-P, -D-LC-P, -D-P, -D-LC-M, -D-A-M, -D-M	PT-TW001-D-SM	TP-03
-07	-D-A-P, -D-LC-P, -D-P, -D-LC-M, -D-A-M, -D-M	PT-TW001-D-SM	TP-03
-02, -09	-S-LC-P, -S-A-P	PT-TW002-S-SM	TP-03
-03, -04	-S-LC-P, -S-A-P, -S-P	PT-TW002-S-SM	TP-03
-07	-S-LC-P, -S-A-P, -S-P	PT-TW002-S-SM	TP-03
-06	-D-LC	PT-TW001-D-SM	TP-03
-06	NONE, -A, -D	PT-TW001-D-SM	TP-03
-06	-D-A-P, -D-LC-P, -D-P, -D-LC-M, -D-A-M, -D-M	PT-TW001-D-SM	TP-03
-06	-S-LC-P, -S-A-P, -S-P	PT-TW002-S-SM	TP-03

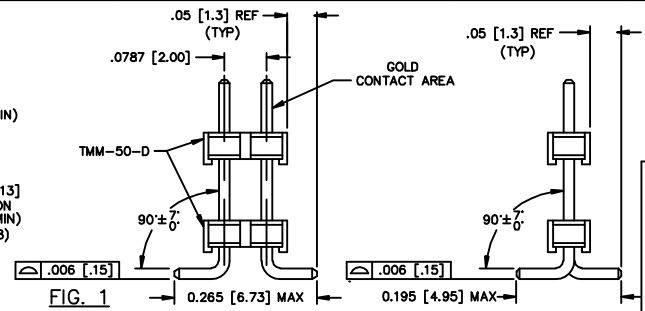
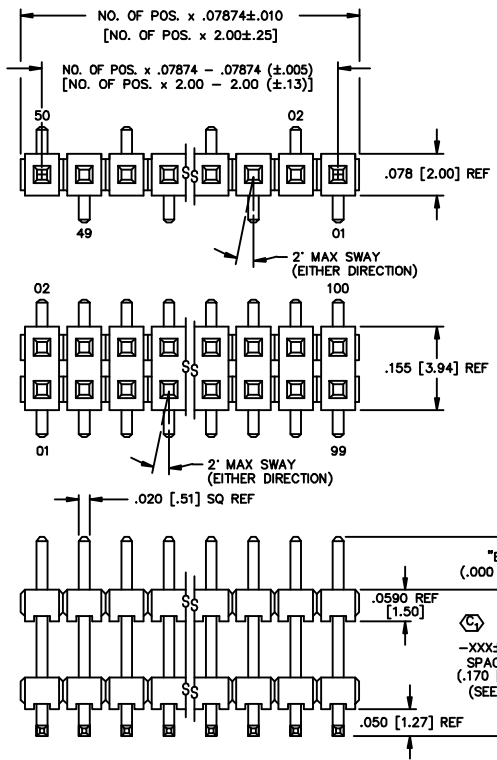

PATENT NUMBERS  
 5713755 / 5961339

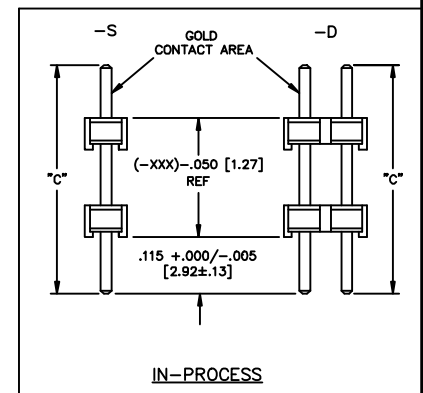

MATERIAL:  
 INSULATOR:  
 LIQUID CRYSTAL POLYMER  
 COLOR: BLACK

TERMINALS:  
 PHOSPHOR BRONZE

EXISPROV/ASSEMBLY/2MM TW-SM

**samtec**

520 PARK EAST BLVD. NEW ALBANY, INDIANA 47150  
 PHONE (812) 944-6733 P.O. BOX 1147  
 CODE 55322

MADE BY:  
 BRYANT 3-8-93 TW-XX-XX-XXX-X-XXX-SM-XXX-XX

PROPRIETARY NOTE  
 THIS DOCUMENT CONTAINS INFORMATION CONFIDENTIAL AND PROPRIETARY TO SAMTEC INC. AND SHALL NOT BE REPRODUCED OR TRANSMITTED IN ANY FORM OR BY ANY MEANS, ELECTRONIC OR MECHANICAL, INCLUDING PHOTOCOPYING, RECORDING, OR BY ANY INFORMATION STORAGE AND RETRIEVAL SYSTEM, WITHOUT THE EXPRESS WRITTEN CONSENT OF SAMTEC INC.